

Model No: MFD-1102 Food Waste Disposer

Specification Sheet

PRODUCT SPECIFICATIONS

Motor Power:	0.5 Hp / 400W
RPM:	3600
Special Features:	<ul style="list-style-type: none"> •Durable stainless steel flange with sound insulation and splash guard. •Pure copper induction motor •Air Switch •Large 1200ml grinding capacity featuring overload protection. •Upgraded 5-stage grinding system to prevent sewer pipe blockage. •Space-Saving:it fits neatly under your sink •Designed for hassle-free installation •Bladeless design
Voltage:	220V / 50hz
Current:	1.5 Amp
Motor Type:	Permanent Magnet Pure Copper DC Motor
On/Off Control:	Air Switch
Height:	370mm (14.5 ")
Base Width:	169mm (6.7 ")
Mouth Width:	85 mm (3.3 ")
Drain Connection Size:	40*600mm / 1.6" *23.6"
Max Sink Thickness	20mm / 0.8"
Internal Grind Component Material	Stainless Steel
Grinding Chamber Capacity	1200ml
Sound Level	< 60 db
Color	Black
Machine Net Weight	4.7 Kgs
Included Accessories	Drainage Hose, T-Connector, Air Switch

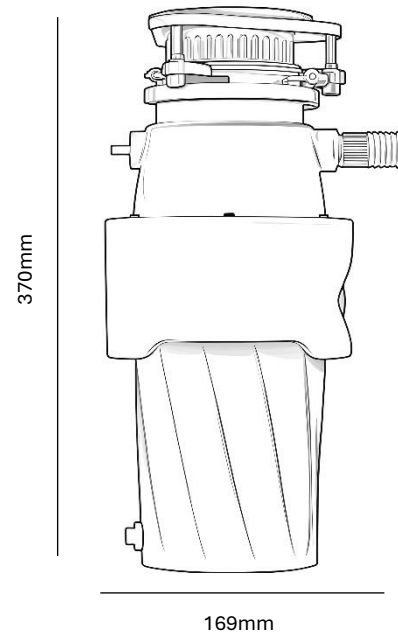

Note:

• Manual measurement of various sizes has a certain error. Please refer to the actual product!• The product may be slightly different from the picture due to the display of lights and displays.

For Warranty information and terms and conditions about this product, please [click here](http://www.morzze.com) or visit www.morzze.com